

memo	approval	date	scale	お客様	name
	check	design	1 / 1	No.	No.

EP24の取付について

スクレッパー等で軽く面取りして下さい。

①図の←部を面取りをしてください。
②ブラハンマー等で軽く打込んでください。

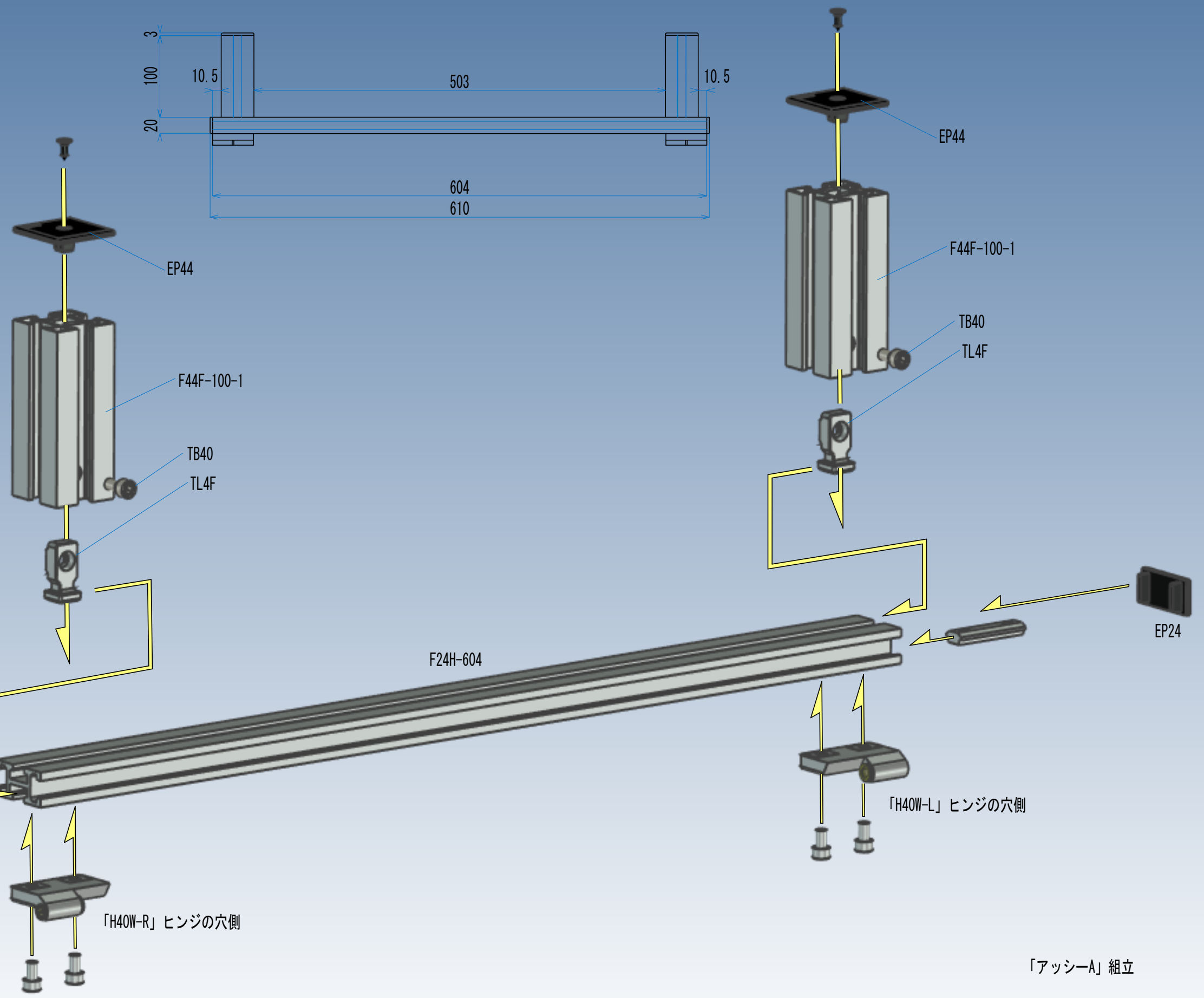
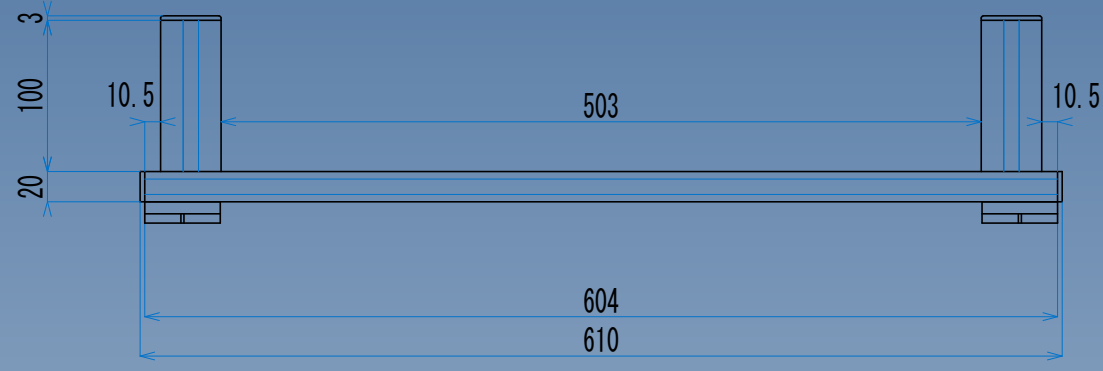

「アッシーA」組立

memo	approval	date	scale	お客様	name
	check	design	1 / 1	No.	No.
LECOFRAME				2024_FFU_Assembly	
				ダンパー・スウィングマウント組立_2	
				TEL 052-739-2901 FAX 052-739-2902	
				YUKI LABORATORY	

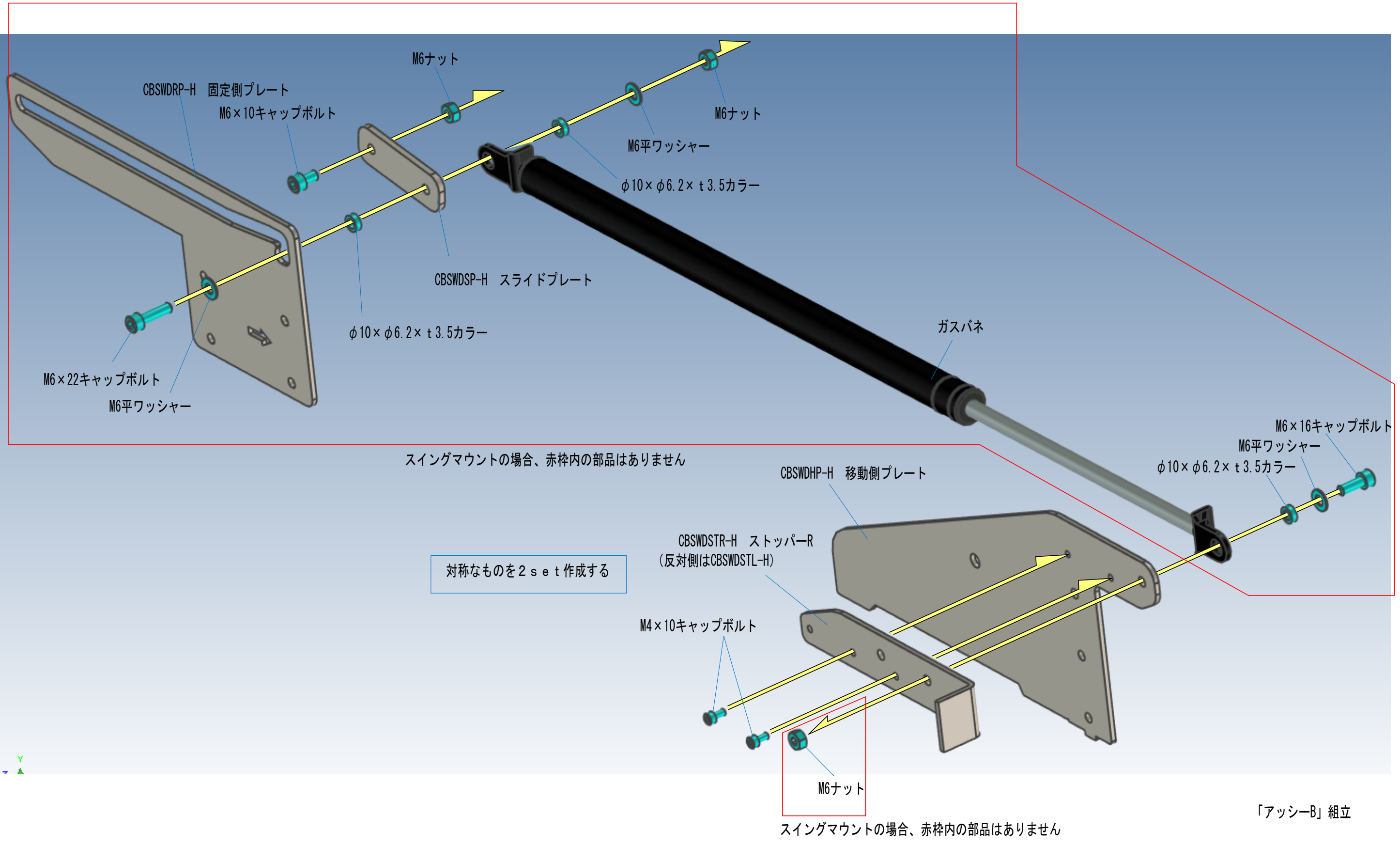

memo	approval	date	scale	お客様	name
	check	design	1 / 1	No.	No.
LECOFRAME				2024_FFU_Assembly ダンパー・スイングマウント組立_3 TEL 052-739-2901 FAX 052-739-2902	
				YUKI LABORATORY	

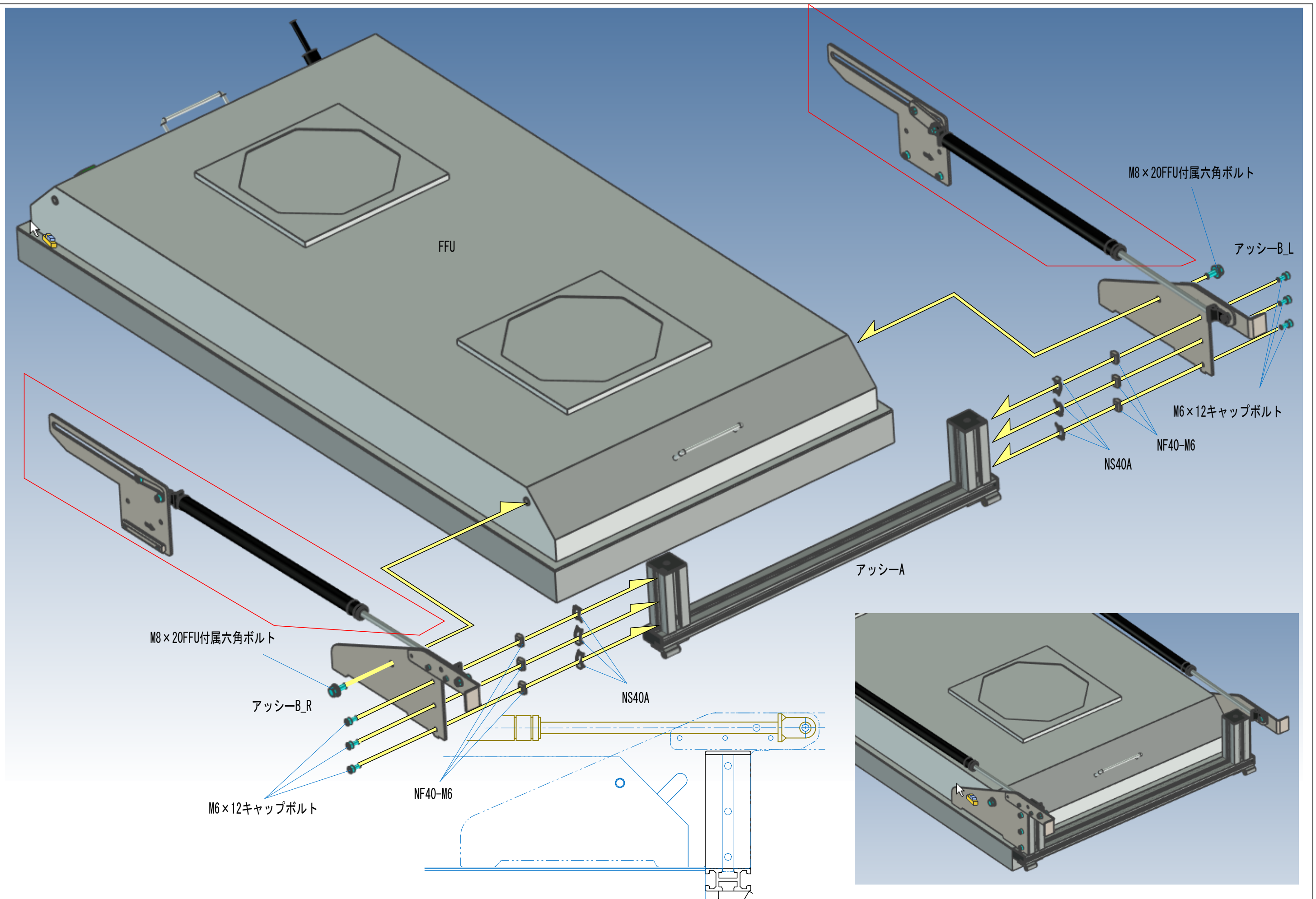

memo	approval	date	scale	お客様	name
	check	design	1 / 1	No.	No.

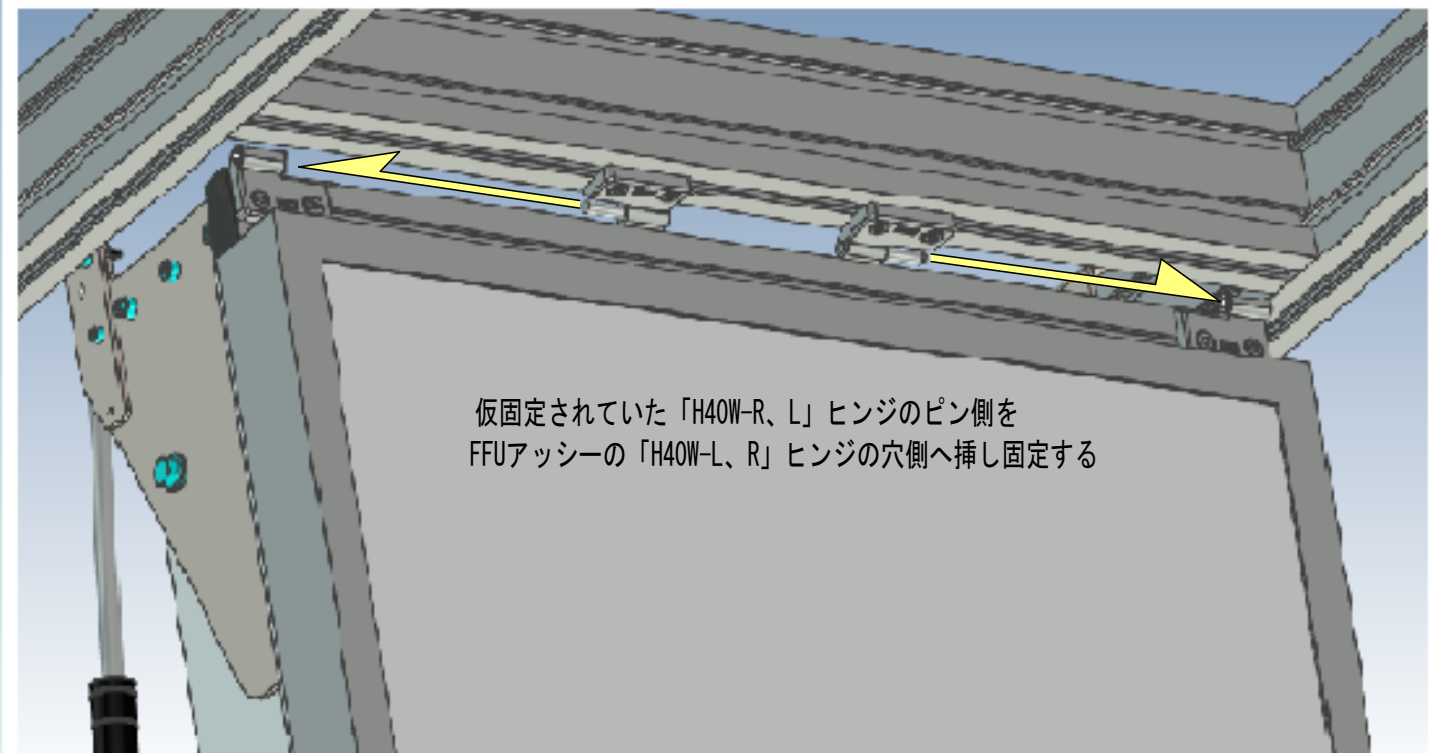
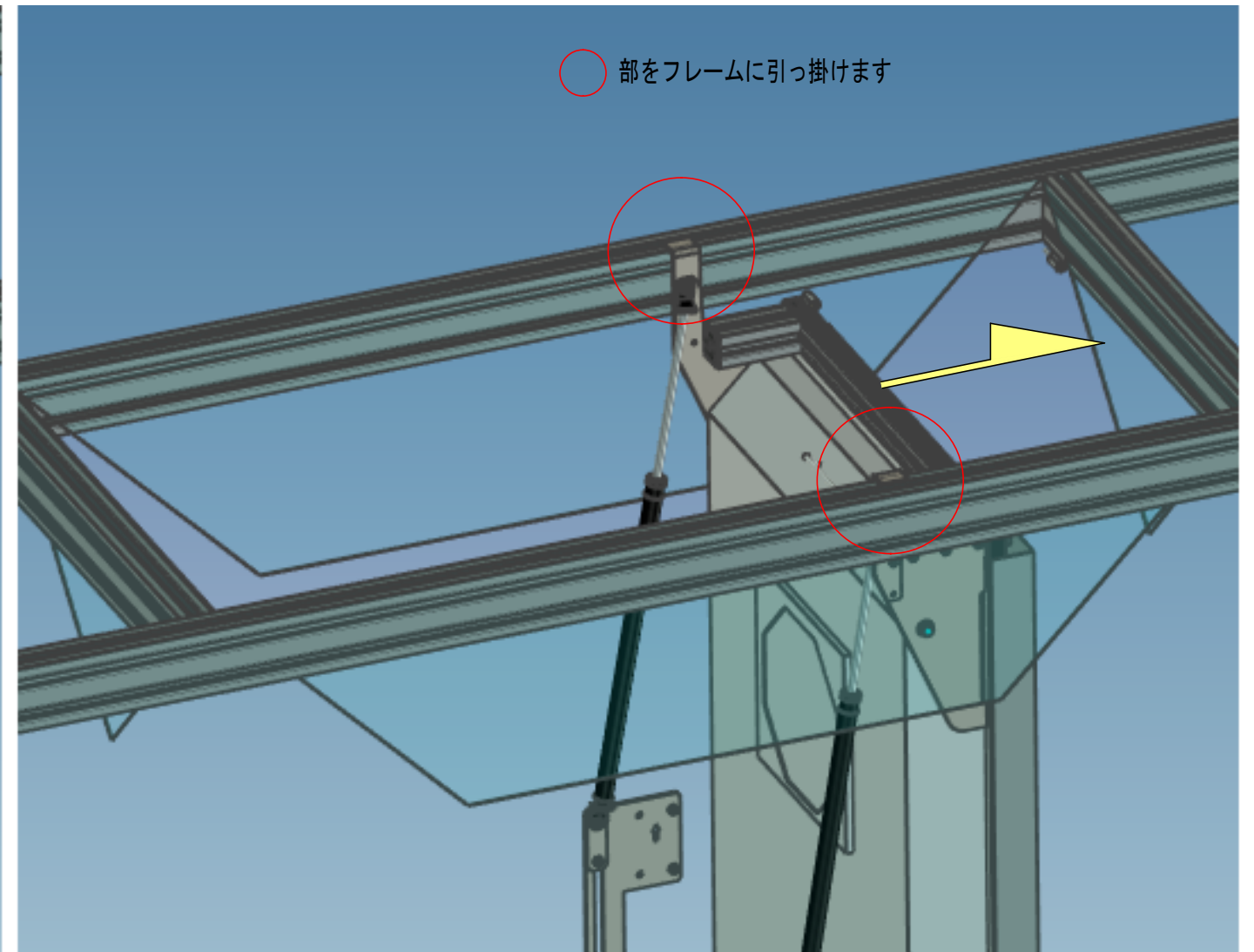
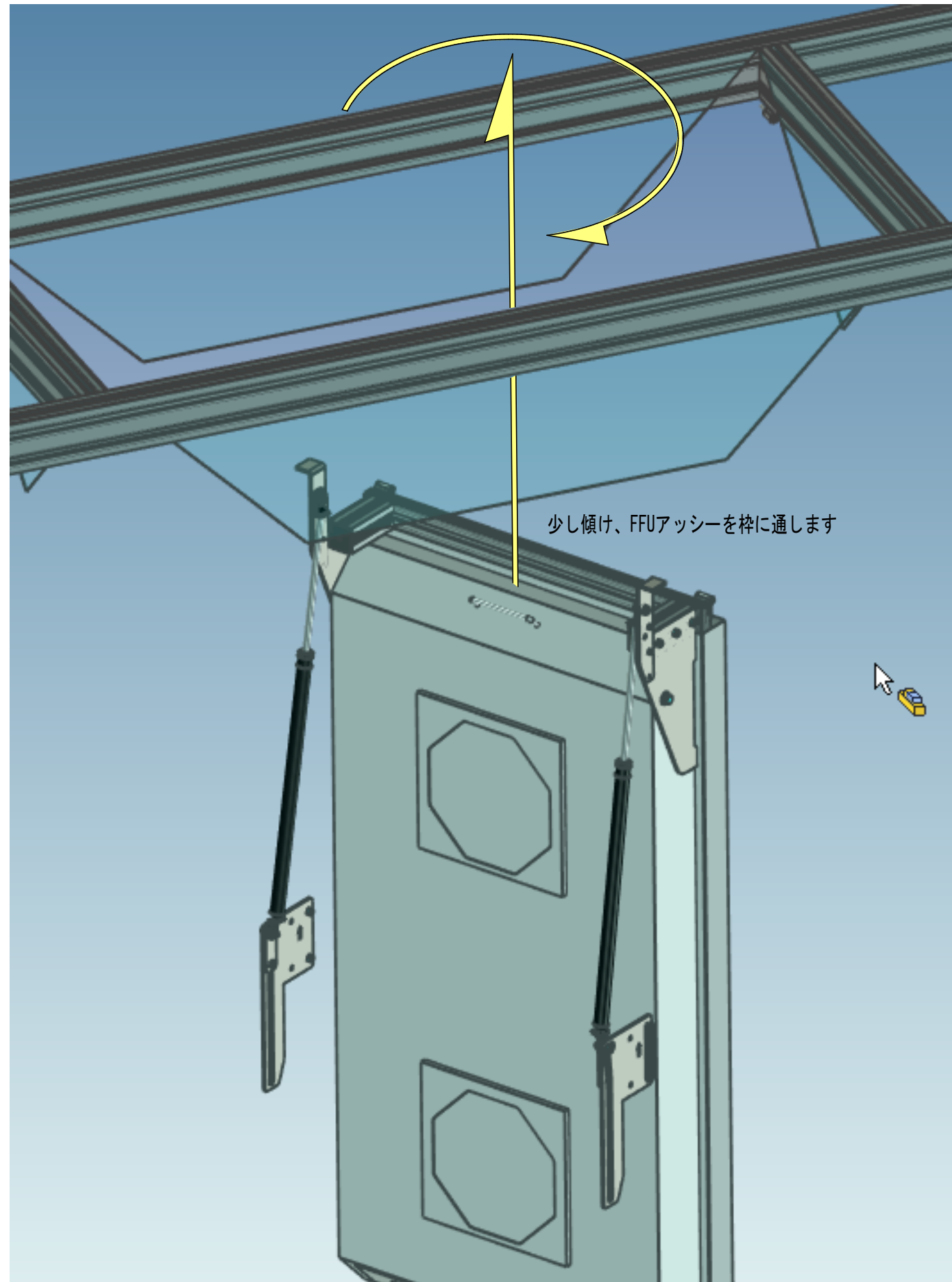

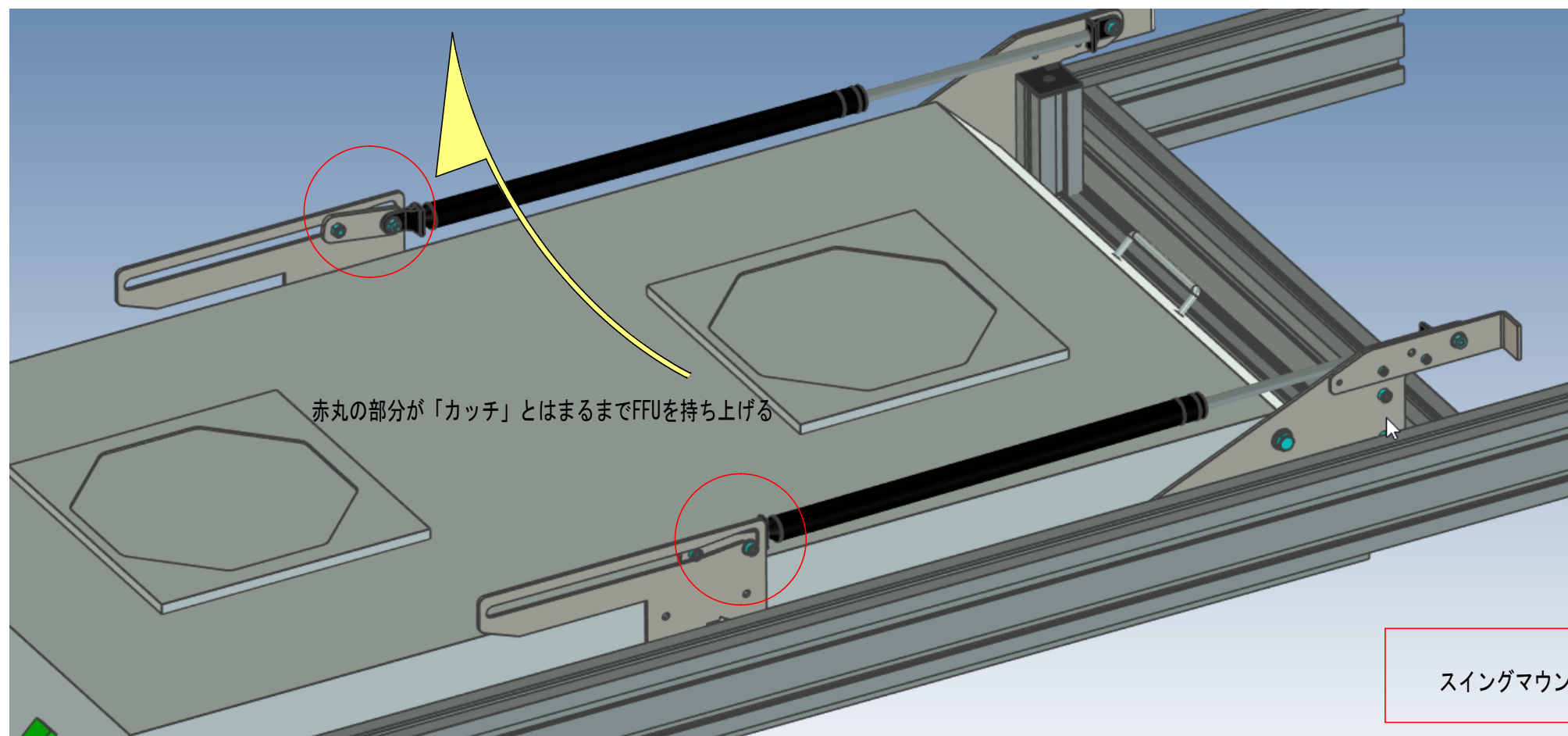
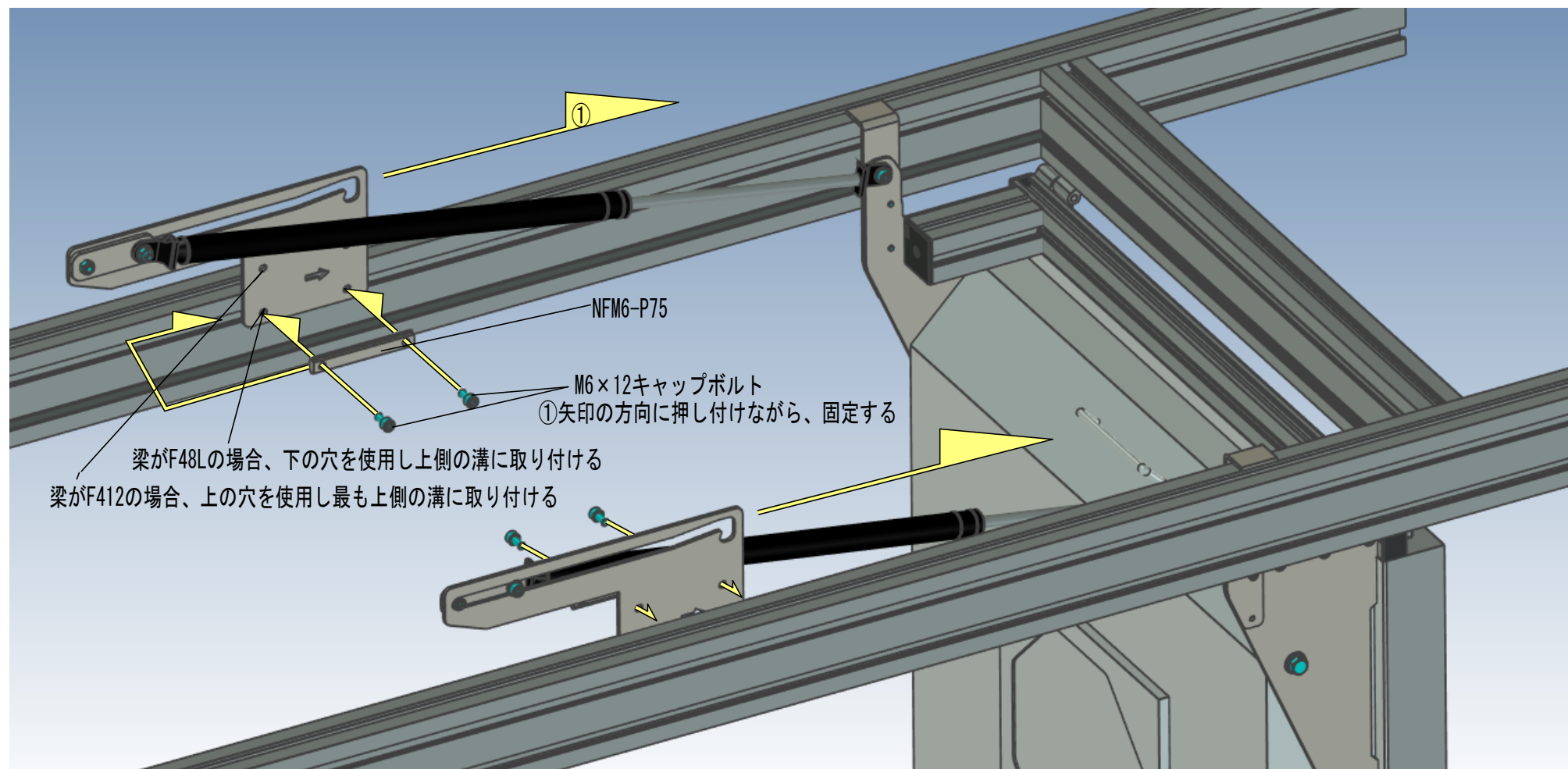

スイングマウントの場合、このページは不要です

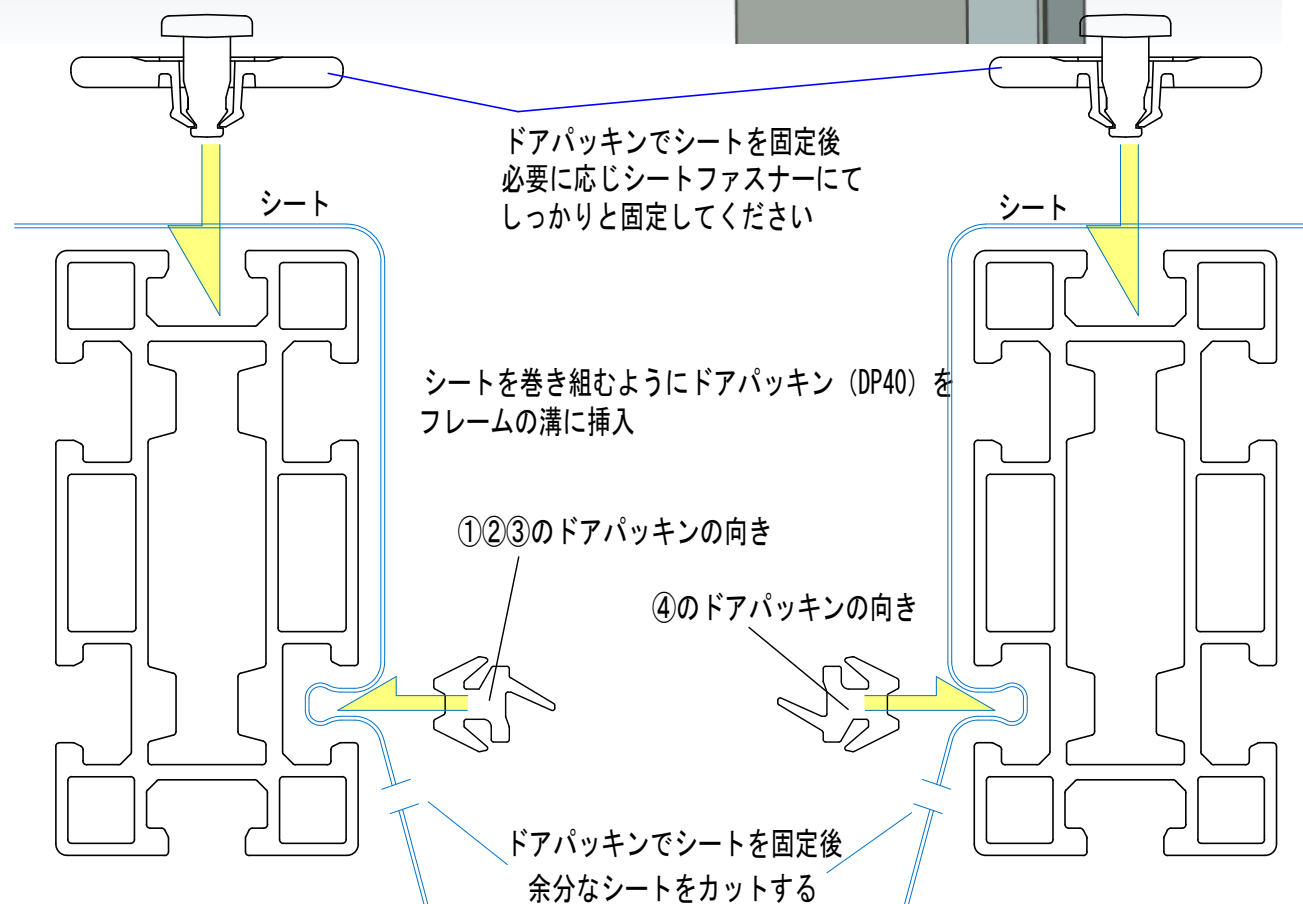
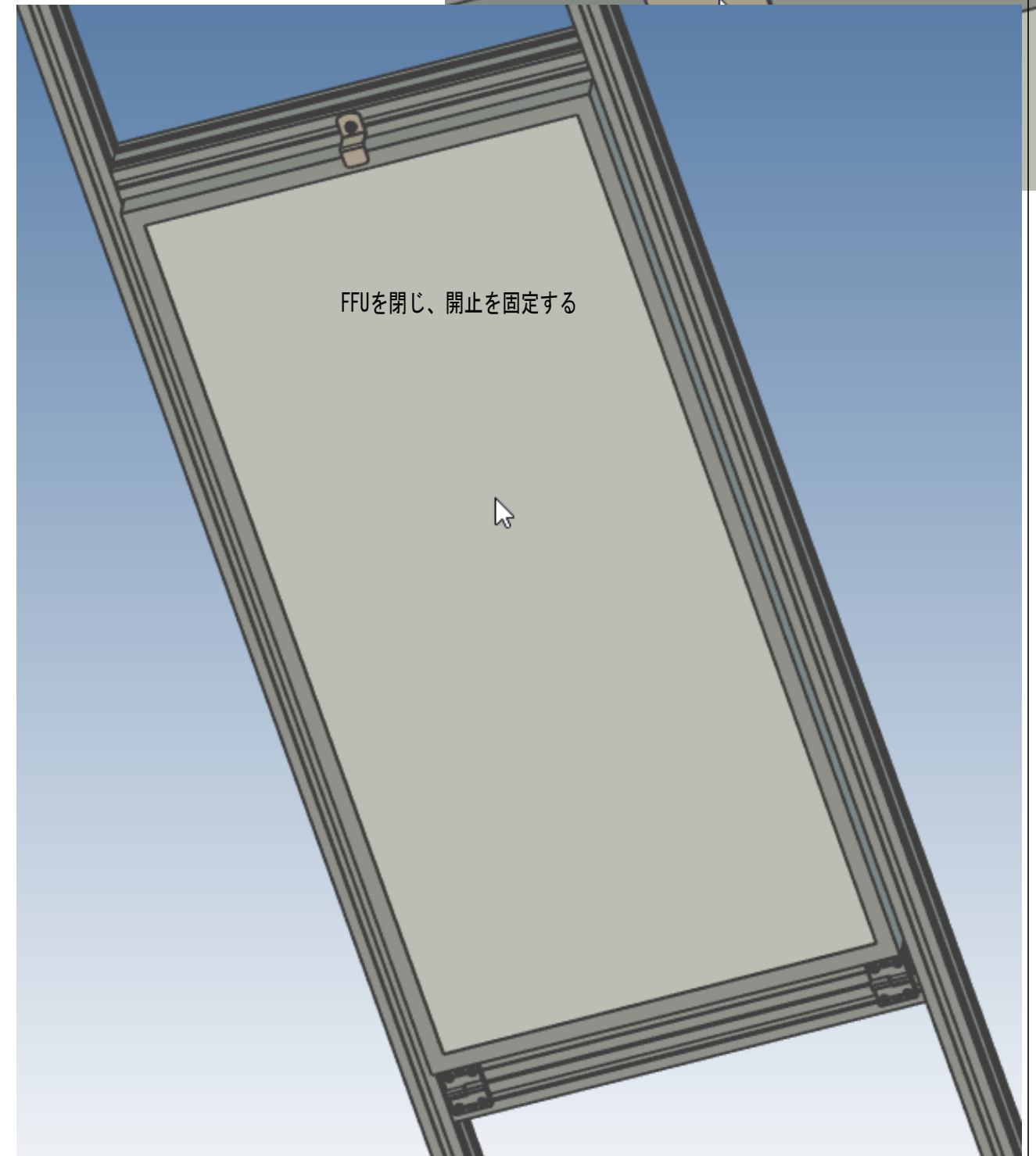
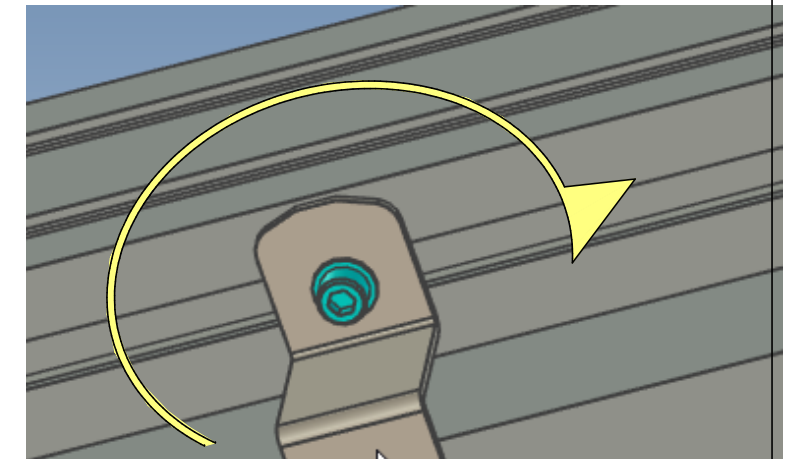
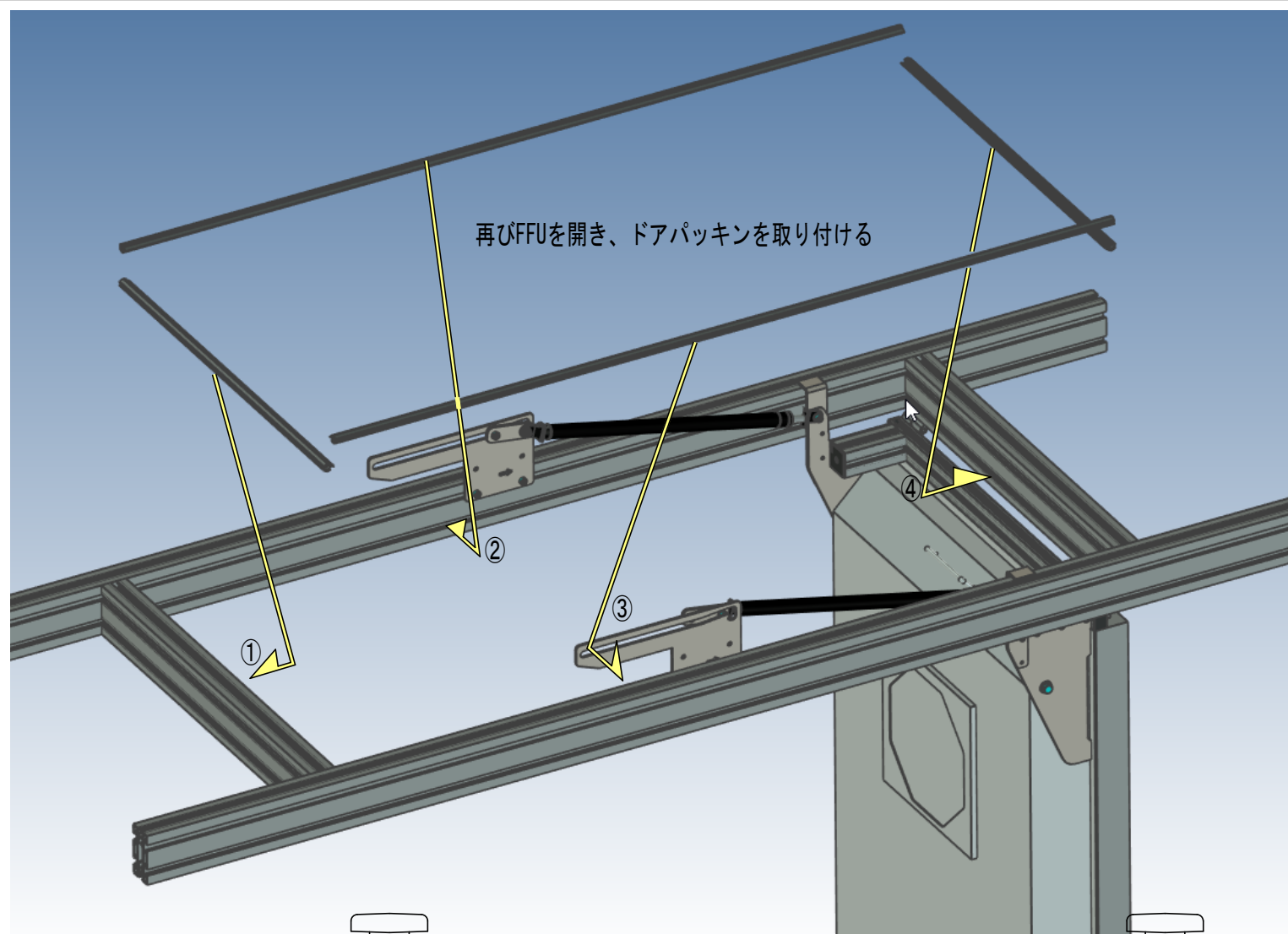

memo	approval	date	scale	お客様	name
	check	design	1 / 1	No.	No.